

PAPER • OPEN ACCESS

Experimental investigation for optimum compression ratio of single cylinder spark ignition engine

To cite this article: Adnan N Ahmed *et al* 2018 *IOP Conf. Ser.: Mater. Sci. Eng.* **454** 012003

View the [article online](#) for updates and enhancements.

You may also like

- [The study on the influence of utilizing n-butanol at fuelling spark ignition engines](#)
Cristian Sandu, Constantin Pan, Niculae Negurescu et al.
- [The study of cyclic variability at a n-butanol spark ignition engine fueled](#)
Cr Sandu, C Pana, N Negurescu et al.
- [The study of the spark ignition engine performance at fueling with n-butanol-gasoline mixture](#)
Cr Sandu, C Pana, N Negurescu et al.



Free the Science Week 2023 April 2–9

Accelerating discovery through
open access!

 www.ecsdl.org [Discover more!](#)

The banner features a dark blue background with a futuristic, glowing blue interface. A hand is shown pointing at a central circular element that contains a white padlock icon, symbolizing open access. The text is in white and light blue, with the ECS logo and website URL in white.

Experimental investigation for optimum compression ratio of single cylinder spark ignition engine

Adnan N Ahmed ¹, Zuhair H Obeid ¹ and Alauldinn H Jasim ¹

¹ Al-Mussaib Technical Institute, Al-Furat Al-Awsat Technical University, 51009
Babylon, Iraq.
Email: adnan.noori1955@gmail.com

Abstract. The present experimental investigation is intended to find the optimum compression ratio (CR) of single cylinder-spark ignition engine (SIE). In order to improve the performance characteristics of SIE includes improving brake thermal efficiency (BTE) and reducing brake specific fuel consumption (BSFC) which represents the main targets of this study. The volume of combustion chamber was altered by changing the thickness of cylinder head gasket, and keeping other components, that form the geometry shape of combustion chamber, constant to obtain various clearance volume and consequently variable compression ratios (VCR_s). This altering permitted to have different values of CR_s of 7, 7.5, 8, 8.5, and 8.7 at engine speeds of 2600 and 2800 rpm at different loads. The results showed that BTE was increased by an average of 13 % with increase of CR from 8.5 to 8.7 and it was decreased by an average of 7.5 % with decrease of CR from 8.5 to 7 at an average speed. Also, it was found that BSFC was decreased with an average of 11 % as CR was increased from 8.5 to 8.7, whereas BSFC was increased with an average of 4.5 % as CR was decreased from 8.5 to 7 at an average speed. Based on these results, it is clearly obvious that the optimum CR is 8.7.

1. Introduction

There is a worldwide pressure to reduce automotive fuel consumption and exhaust emissions as well as improving BTE for SIE as it fights for market share with the diesel [1]. The need to improve the performance characteristics of SIE requires raising the CR below knocking limit. The CR is a factor that influences the performance characteristics of internal combustion engine (ICE). Aina et al (2012) [2] studied the influence of CR on BTE, Brake power, brake mean effective pressure (BMEP), and BSFC of the Ricardo variable compression ratio spark ignition engine. And by applying CR_s of 5, 6, 7, 8, and 9 at engine speeds of 1100 to 1600 rpm, in increments of 100 rpm, The results showed that as CR increases, the actual BSFC decreases averagely by 7.75 %, BTE improves by 8.49 %, and brake power also, was improved by 1.34 %. Also, they obtained maximum CR corresponding to maximum brake power, BTE, BMEP, and lowest BSFC was 9. Venkateswara (2015) [3] made an attempt to investigate the effect of CR on performance characteristics of diesel engine through conducting experiments on a VCR engine at CR of 14, 16, 18, and 20 and by analysing the performance characteristics like BTE and BSFC, it was observed that the increase in CR performance of engine increased appreciably with less BSFC. Attir et al (2015) [4] studied and evaluated the effect of CR on performance of single cylinder four stroke (VCR) diesel engine with the engine working at different loads at CR_s of 16, 17, and 18. The tests were performed on engine speed of 1500 rpm and the evaluated performance parameters included BTE and BSFC. Results showed an appreciably enhancement in BTE and BSFC at CR of 18.



Pariyadarsini et al (2015) [5] paper presented the effects of spark timing and CR on the performance of a four stroke single cylinder SIE. The study evaluated the results in the area of SIE and it was assessed by studying its performance characteristics relative to find the optimum. Experiments were conducted at CR of 3.5 to 9. The increased CR had resulted in an increased BTE, whereas BSFC decreased with increased CR.

Ramalingam et al (2015) [6] aimed to find the effects of the engine design parameters on CR and fuel injection timing jointly on the performance with regard to BSFC and BTE, also it was found that the combined increase of CR and injection timing increases the BTE and reduces BSFC while having lower emissions.

Taremwa et al (2016) [7] research in which a single cylinder four stroke diesel engine was operated at different CR_s 14: 1, 16: 1, and 18:1. The performance and emission characteristics were studied, BTE, and mechanical efficiency were found to be the highest at CR of 18:1. BSFC was also found to be the lowest at CR of 18:1.

Alqahtani et al (2017) [8] aimed to model and simulate a simple single-cylinder two-stroke opposed-piston engine and minimize fuel consumption and heat loss, in order to meet this aim, six combinations of CR_s (12, 13.5, 15, 16.5, 18 and 19.5) were analysed in this study with engine speed running at 420 rpm and 1500 rpm. In addition to the CR_s, the effect of stroke-to-bore ratios on performance was investigated. Various values of stroke/bore ratios, whilst maintaining a constant swept volume, port geometry, and combustion timing, their effect on fuel combustion, and heat loss were analysed in the previous study. A comparison between the two engine speeds with increasing combinations of CR_s and the stroke/ bore ratios had revealed minimal differences in peak pressure, peak temperature, indicated mean effective pressure (IMEP), indicated specific fuel consumption, indicated efficiency and total heat loss. VCR technology has been recognized as a method for improving the automobile engine performance, BTE, fuel economy with reduced emission. The main future of the VCR engine is to operate at various CR_s by changing the combustion chamber volume depending on the vehicle performance needs. The need to improve the performance characteristics of the ICE has necessitated the current investigation. Increasing the CR to improve on the performance is an option. The CR is a factor that influences the performance characteristics of ICE_s.

The research of Abhishek et al (2015) [9] is an experimental investigation of the influence of the CR on the brake power, BTE, BMEP, and BSFC of Kirloskar VCR dual fuel engine. Through applying CR_s of 14, 15, 16, and 18 and engine loads of 3 kg to 12 kg in increments of 3 kg were utilized for diesel.

The influence of CR on the engine performance, BTE, BSFC of VCR compressed natural gas (CNG) engine was studied by Ramachandran et al (2016) [10]. CR_s of 8, 9, 10, 11, 12 and 13 and engine speeds of 1200 to 1800 rpm in increments of 100 rpm were utilized in the present study, the effect of different CR_s was applied and optimum CR was established for a dedicated CNG engine. The results showed that with the increase in CR, the performance characteristics on power, torque, BTE and BSFC are improved. The emission characteristics except nitrogen oxides are found to be better for CNG.

There are different methods to obtain different CR_s such as changing the cylinder head cavity volume, variation of combustion chamber height, and variation of piston height:

1.1. Cylinder head cavity volume (combustion chamber volume in the cylinder head)

The cylinder head cavity volume is playing a significant role in variation of CR. This cylinder head cavity volume is separately measured for calculating the clearance volume. Cylinder head cavity volume is at higher side then CR is at lower side and when cylinder head cavity volume is at lower side then CR is at higher side. So, every researcher aims to keep CR at higher side for better performance by using lower cylinder head cavity volume.

1.2. Top dead center volume (piston to deck volume)

The top dead center (TDC) volume is also an important parameter which affecting on the variation of CR. This volume is formed when piston is rest at TDC and it is measured to calculate the clearance volume in addition to the cylinder head cavity volume. If TDC volume is at higher side then CR is at

lower side and vice versa. This TDC volume always keeps at lower side for better engine performance.

1.3. Cylinder head gasket volume

The volume of the cylinder head gasket also has an effect on the volume of the combustion chamber and as a result the various CR were obtained. This volume is measured for calculating clearance volume in addition to cylinder head cavity volume and TDC volume. For better engine performance, the cylinder gasket volume was kept at lower side.

1.4. Piston height from piston pin to crown

The effect of piston height on the variation in CR is little. The effective piston height is helpful for lowering clearance volume. If the piston height is at higher side, then TDC volume is at lower side and vice versa. Then for better engine performance keep piston height at higher side [11].

1.5. Piston/cylinder volume

It is the volume of cylinder-piston clearance above the piston's rings, this little area also plays a small role in determining the compression ratio as shown in Fig. 2.

1.6. Piston chamber volume

It is the volume of combustion chamber in the piston, in the case of using dish top piston (positive volume) where this dish volume is added to the remaining factors that forming the clearance volume. Whereas in the case of using dome top piston (negative volume), in this case the dome volume is subtracted from the clearance volume.

The present experimental investigation focuses only on the thickness of cylinder head gasket and keeps the other components that form the volume of combustion chamber, constant. In other words, the remaining other factors are constant, like cylinder head cavity volume, top dead center volume, and piston height from piston pin to crown. So, the significant factor is thickness of cylinder head gasket. By controlling thickness of gasket, different CR_s can be obtained and the optimum one is that with better BTE and less value of BSFC.

2. Experimental work

2.1. Experimental setup

The experimental work was carried out on "S.I- Engine- AC Generator System Test Rig "as shown in Figure 1, which consists of three separated main units. The first unit is "S.I- Engine- AC Generator System "as one compact unit, the second unit is separately "Resistive Load Bank ", and the third unit is instrumentation panel. All components that form geometry shape of combustion chamber are demonstrated in Figure 2. it can be noticed that the piston type of S.I-Engine is a flat top piston, so the piston chamber volume is negligible whereas the other factors are taken into account. The present experimental investigation highlights on the thickness of compressed cylinder head gasket to obtain various CR_s as shown in Figure 3, it is clear that for better engine performance, the gasket thickness is kept at lower side.

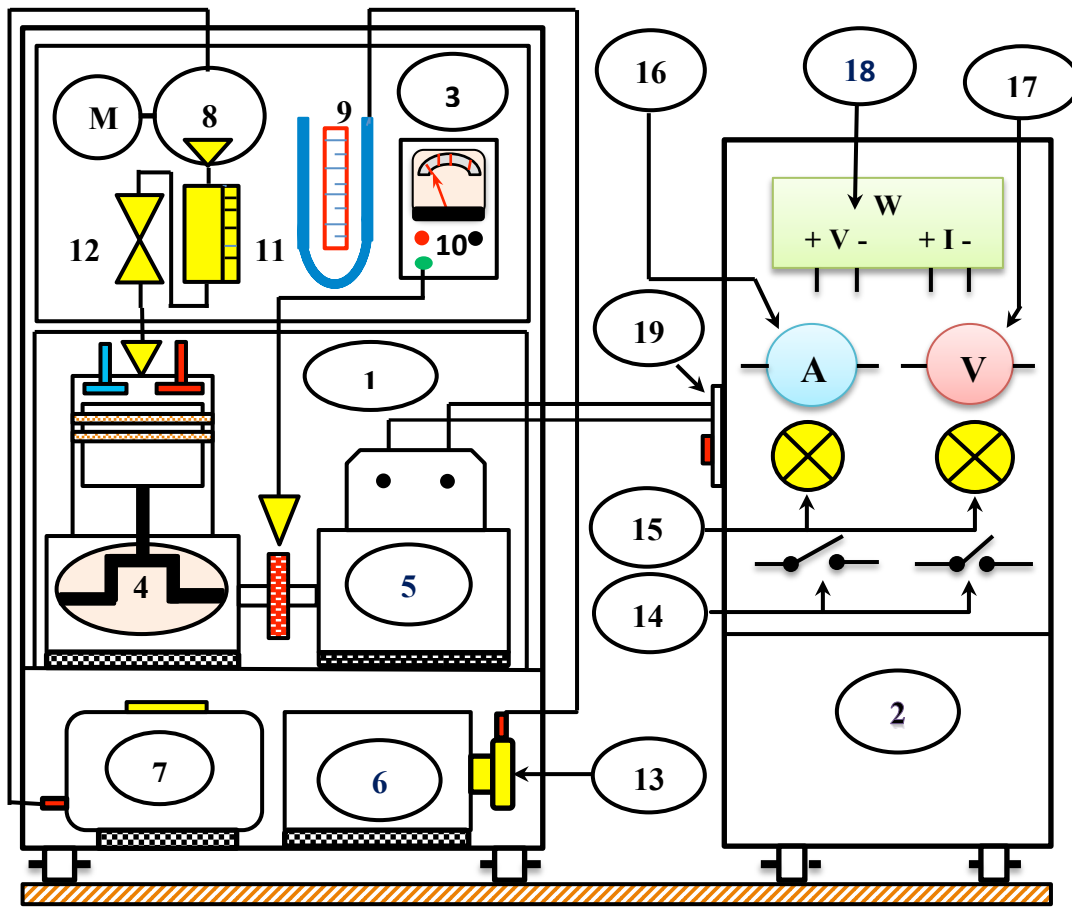

Figure 1. Schematic diagram of experimental set-up for single cylinder SIE. 1-S.I-Engine-AC Generator System,2-resistive load bank,3-instrumentation panel,4-single cylinder SIE,5-AC-generator type dynamometer,6-air box,7-fuel tank,8-electric fuel pump,9-U-tube water manometer,10-digital Tachometer Indicator connected with speed sensor,11-Burette,12-(2-way valve),13-air box nozzle,14-loading switches,15-Loading indicator lights,16-AC-digital ammeter,17-AC-digital voltmeter,18-electrical energy meter,19-Loading main switch.

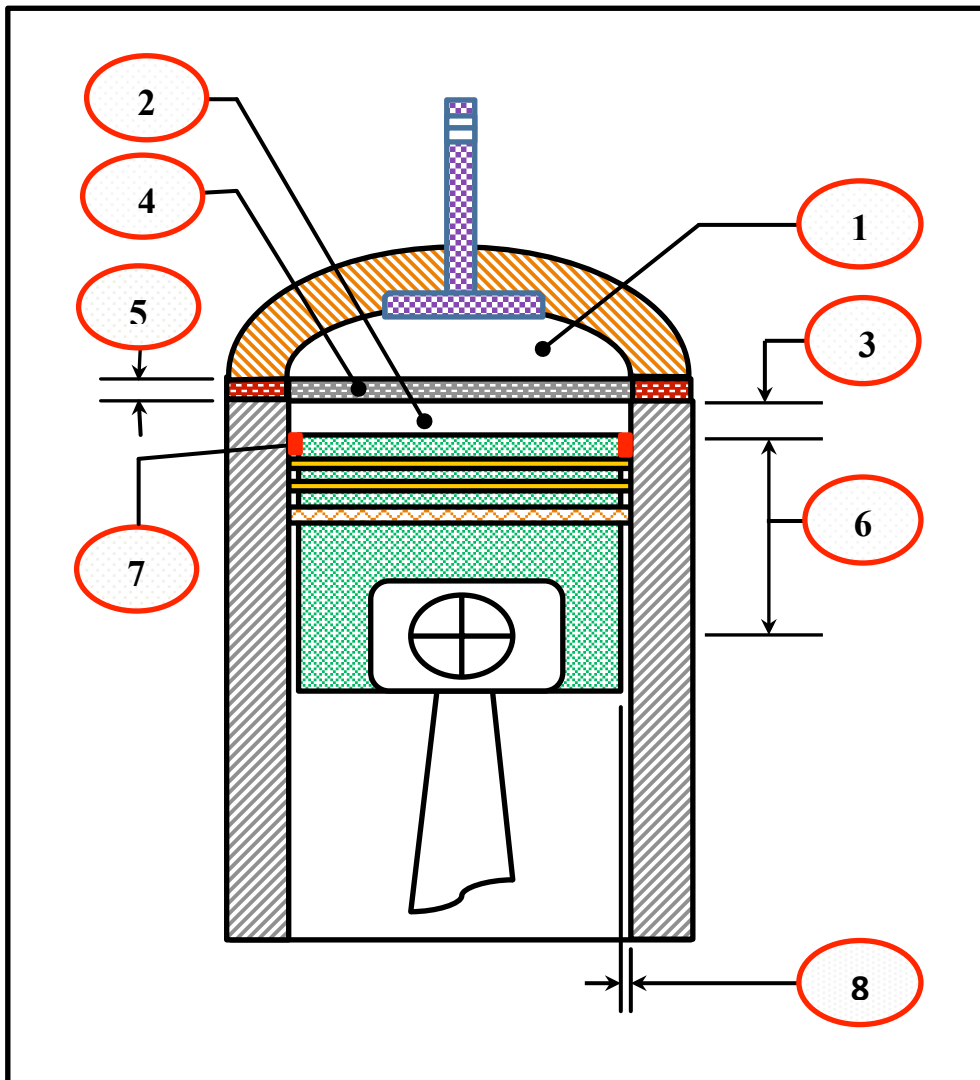

Figure 2. Details of combustion chamber geometry of reciprocating ICE. 1-cylinder head cavity volume (combustion chamber volume in the cylinder head), 2-TDC- volume (piston to deck volume), 3-piston to deck clearance, 4-cylinder head gasket volume, 5- compressed head gasket thickness, 6-compression height(pin height), 7-piston/cylinder volume, 8-piston/cylinder clearance.

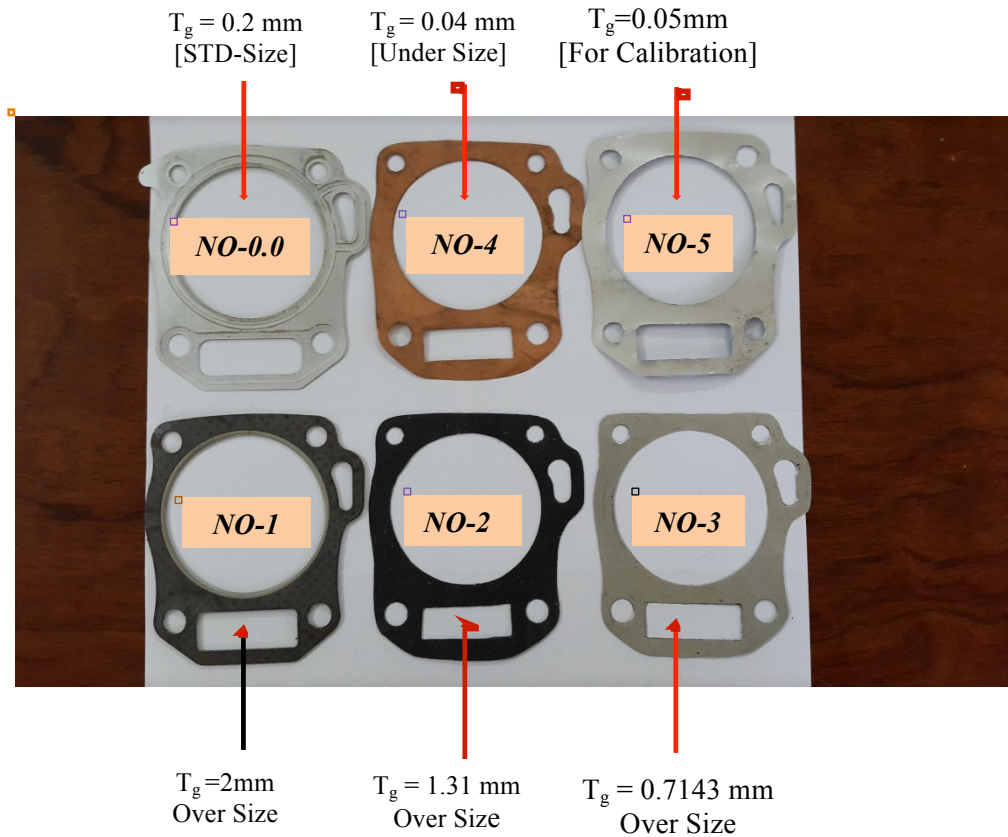

Figure 3. Different thicknesses of compressed cylinder head gasket to obtain various CR_s of 7, 7.5, 8, 8.5 and 8.7 respectively.

2.1.1. S.I- Engine- AC Generator unit. The test rig engine is a single cylinder (SIE), four stroke, and forced air cooled engine. The technical specification is shown in Table 1.

Table 1. Technical specification of test rig engine.

Sr. No.	Description	Specification
1	Model	JF200E
2	Engine Type	Single Cylinder 4 - Stroke Spark Ignition Engine With Forced Air-Cooled
3	Displacement	196 CC
4	Bore*Stroke	68*54 mm
5	Max .Output	6.5 HP/3600 rpm
6	Compression Ratio	8.5:1
7	Bore / Stroke	1.26:1
8	Method of Loading	AC-Generator With Resistive Load Bank
9	No. of Cylinder	Single
10	Ignition System	T.C.I
11	Starting System	Cranking Motor

The test rig engine is directly connected to the AC- Generator type dynamometer for electrical loading purposes. The technical specification of AC- Generator is shown in Table 2.

Table 2. Technical specification of AC- generator.

Sr. No.	Description	Specification
1	Model	JD 3500 EBWH
2	Type	Single phase AC- voltage 220 V, 50 Hz
3	Voltage regulator	AVR / Capacity
4	AC output	3 kVA
5	Power factor	1

2.1.2. Resistive load bank unit (RLB). A load bank is a device which develops electrical loads and applies this load to an electrical power source like AC- Generator and then converts or dissipates the result power output of the source. The positive type load bank, the most common type, provides equivalent loading for AC- Generator. The load of the present resistive load bank is created by the conversion of electrical energy to heat (by using small power resistors as a load). This heat has to be dissipated from the load bank by electric air fan. The RLB is provided with digital ammeter, digital voltmeter, and energy meter in order to measure electrical loads that are applied on the AC- Generator.

2.1.3. Instrumentation panel unit. The instrument panel unit is equipped with several measurement systems. The first unit is fuel measurement system in which fuel is pumped by an electrical fuel pump from the fuel tank and then flows through a measuring graduated burette by using 2-way valve to the engine cylinder. By measuring the time that the discharged fuel takes until being consumed and knowing the density of the fuel, the mass flow rate could be obtained.

The second unit is an air intake measurement system. The atmospheric air is drawn into the engine cylinder through the air box. The U-tube water manometer is provided to measure the pressure drop across air box nozzle provided in the intake pipe of the air box. This pressure drop is used to calculate the volume of air drawn into the cylinder.

The third unit is engine speed measurement rig. Engine speed is measured by using accurate digital tachometer indicator connected with speed sensor.

2.2. Experimental determination of performance characteristics

The test rig engine is directly coupled to the AC- Generator type dynamometer which serves as a loading device. The power generated by the AC- Generator is absorbed by using resistive load bank which is provided with a digital ammeter, digital voltmeter, and energy meter in order to measure power generated. The volume flow rate of fuel can be calculated by measuring the time taken for specific volume of fuel to be consumed. Whereas the experimental values of the brake power, BTE, and BSFC were also calculated by applying the equations (3), (5), and (6) respectively.

2.3 The basic equations of performance parameters

The basic equations of performance parameters in the present experimental work as shown below [6]:

$$CR = \frac{V_S}{V_C} + 1 \quad (1)$$

Where CR: Compression ratio
 V_S : Swept volume, cm^3
 V_C : Clearance volume, cm^3

$$V_g = \frac{\pi (D_g)^2}{4} T_g \quad (2)$$

Where V_g : Volume of gasket, cm^3
 D_g : Inner diameter of gasket, cm
 T_g : Thickness of gasket, cm

$$B_P = \frac{3600 n}{E_m t \eta_{\text{trans.}}} \quad (3)$$

Where B_P : engine brake power, kW
 n : No. of revolution of energy meter
 E_m : Energy meter constant, rev/ kW.hr
 t : time for " n" revolution of energy meter in sec.
 $\eta_{trans.}$: transmission efficiency

$$\dot{m}_f = \frac{V_f}{t_f} \rho_f \quad (4)$$

Where \dot{m}_f : mass flow rate of fuel, kg/sec
 V_f : measured fuel volume, cm³
 t : time for 10 cc of fuel consumption, sec.
 ρ_f : density of fuel, kg/m³

$$\eta_{b.th} = \frac{B_P}{\dot{m}_f \text{ L.H.V}} \quad (5)$$

Where $\eta_{b.th}$: Brake thermal efficiency
 L.H.V: Low heating value of fuel kJ/ kg

$$B.S.F.C = \frac{\dot{m}_f}{B_P} 3600 \quad (6)$$

Where $B.S.F.C$: brake specific fuel consumption, kg/kW.hr

3. Results and discussion

The maximum CR is limited up to 8.7 in order to avoid detonation phenomena and keeping a good sealing between cylinder head and block cylinder by using minimum thickness of cylinder head gasket. The experimental tests were carried out at different electrical loads at range of no load up to full load and CR_s of 7, 8, 8.5, and 8.7 at engine speeds of 2600 to 3000 rpm. The optimum CR is determined with respect to maximum BTE and minimum BSFC at rated engine speed.

3.1 Performance characteristics analysis

The present experimental investigation highlights on the significant performance characteristics which are BTE and BSFC.

3.1.1. Brake thermal efficiency (BTE): Figure 4. illustrates that the variation of BTE with respect to electrical loads at constant engine speed of 2600 rpm and different compression ratio. The experimental results indicated that the BTE increases with increase in the electrical load for all compression ratios, also the results showed that the BTE increases with increasing in CR_s. The BTE was improved by an average of 13 % as CR increases from 8.5- 8.7 and decreases by an average of 7.5 % as CR decreases from 8.5 to 7. The obtained results from experimental work of this study are similar to results reported by many researchers [13, 14, 15, and 16]. Increasing the load on the engine leads to increase the brake power output.

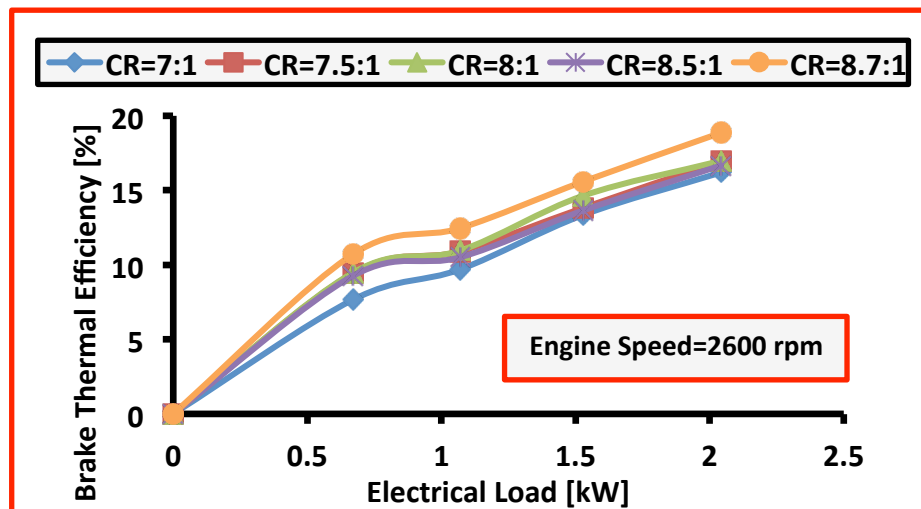

Figure 4. Variation of brake thermal efficiency vs. variation in electrical load At different compression ratios and engine speed of [N=2600 rpm].

Figure 5 shows the variation of BTE versus electrical loads at constant engine speed of 2800 rpm and different CR_s. The results revealed that the BTE increases with the increase in the load for all CR_s. The BTE was improved by an average 11 % as CR increased from 8.5 to 8.7 and decreased with an average of 5 % as CR decreased from 8.7 to 7. It can be noticed that the BTE's values at 2800 rpm are less than that at 2600 rpm, due to that increase in engine speed leads to increase the mass flow rate of fuel more and which consequently increasing the brake power output. And these results are in good agreement with previous studies [13, 14, 15, and 16].

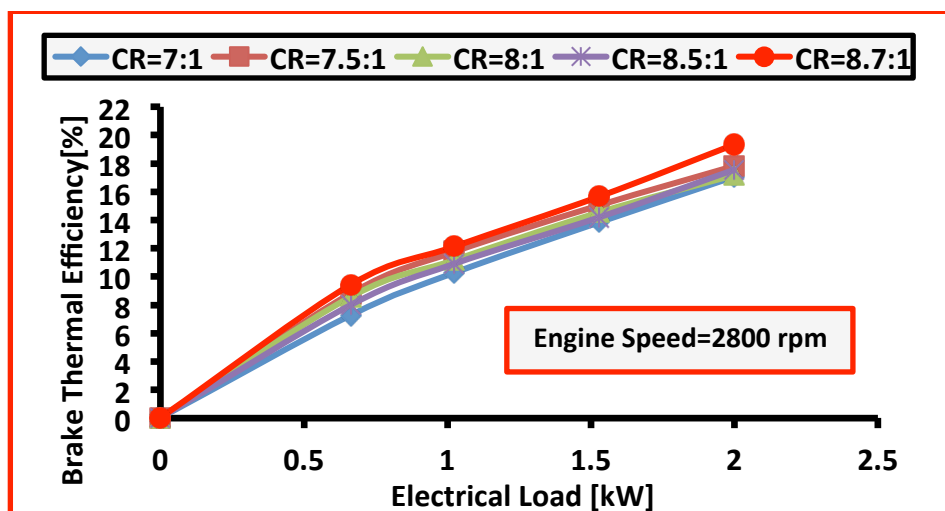

Figure 5. Variation of brake thermal efficiency vs. varying electrical loads at Different compression ratios and engine speed of [N=2800 rpm].

3.1.2. Brake Specific fuel consumption (BSFC). Figure 6 indicates the variation of BSFC with respect to electrical loads at engine speed of 2600 rpm and different CR_s. The experimental results revealed that the BSFC decreases as the electrical load increases for all CR_s, also the results showed that the BSFC decreases as the CR increases. The obtained results showed that the BSFC decreases by an average of 13 % as CR increases from 8.5 to 8.7 and increasing with an average of 7 % as CR decreases from 8.5 to 7. These findings are compatible to many previous researches [13, 14, 15, and 16]. The significant reason for that the brake power is more fuel-consuming at higher loads, also the

BSFC is inversely proportional to that of BTE, so as BSFC decreases the BTE increases. The mathematical formula for BTE is almost reciprocal of that for BSFC.

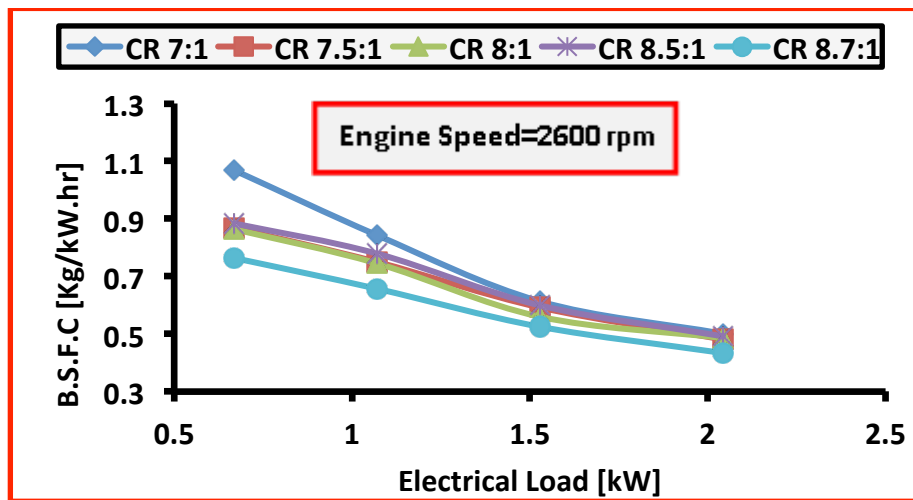

Figure 6. Comparison of the brake specific fuel consumption vs. variation in electrical loads at different compression ratio and $[N=2600 \text{ rpm}]$.

Figure 7 indicates that the variation of BSFC versus electrical loads at different CRs and constant engine speed of 2800 rpm. The experimental results showed that the BSFC decreases with the increasing of electrical loads, also the results indicated that the BSFC decreases as the CR increases, and these results agreed with the results of other researches [13, 14, 15, and 16]. Additionally, the results revealed that the BSFC decreases with an average of 11 % as the CR increases from 8.5 to 8.7 and increasing by an average of 4.5 % as CR decreases from 8.5 to 7. It could be noticed that the results of BSFC at engine speed of 2800 rpm are more than that at 2600 rpm as previously mentioned, due to that increasing engine speed resulting in increasing fuel consumption.

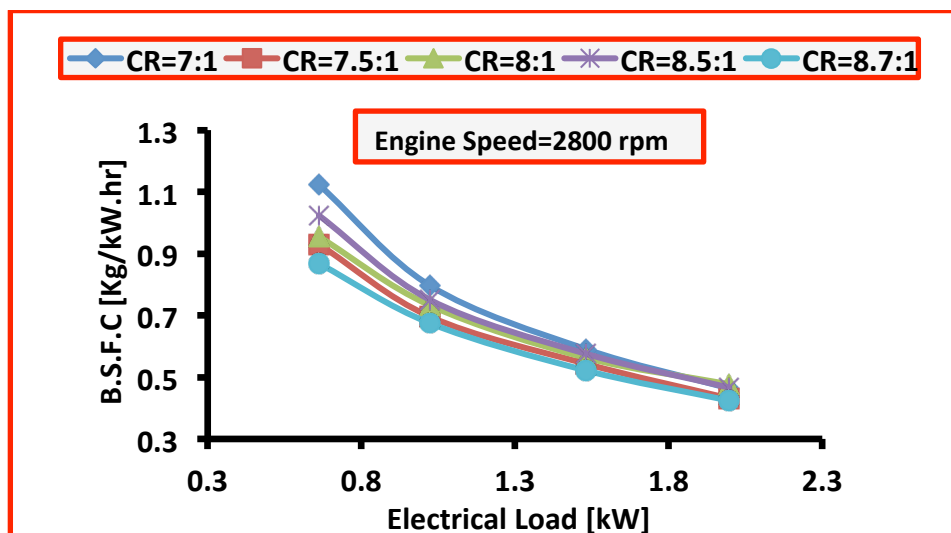

Figure 7. Comparison of the specific fuel consumption vs. variation in electrical loads at different compression ratio and $[N=2800 \text{ rpm}]$.

4. Conclusions

The most significant conclusions from experimental work are summarized as follows:

The BTE increases with increase in electrical loads at all different CR_s and the BSFC decreases as the electrical loads increases at all different CR_s as well as, the optimum CR that gives better performance characteristics is 8.7: 1. It can concluded that the BTE was improved by an average of 13 % as CR increases from 8.5 to 8.7 and it was decreased at an average of 7.5 % as CR decreases from 8.5 to 7 at an average speed. It can also be concluded that the BSFC was decreased at an average of 11 % as CR increases from 8.5 to 8.7 and it was increased with an average of 4.5 % as CR decreases from 8.5 to 7 at an average speed.

5. References

- [1] Shaik A, Moorthi N S V and Rudramoorthy R 2007 Variable compression ratio engine: A future power plant for automobiles- An overview *J. Automobile Eng.* **221**, 1159- 68
- [2] Aina T, Folayan C O and Pam G Y 2012 Influence of compression ratio on the performance characteristics of a spark ignition engine *Adv. Appl. Sci. Res.* **3**, 1915- 22
- [3] Venkateswara R P 2015 Compression ratio effect on diesel engine working with digital biodiesel (JOME)- Diesel blend as fuel *Res. J. Chem. Sci.* **5**, 48- 51
- [4] Attri V J, Sharma V K, Singh S K and Saraswat M 2015 Effect of compression ratio on performance and emissions of diesel on a single cylinder four stroke VCR engine. *Inter. J. Emerging Technol. Adv. Eng.* **5**, 94- 102
- [5] Pariyadarsini I, Krishna M V S M and Devi E N 2015 Study of impact of spark timing and compression ratio on performance of SI engine *Inter. J. Recent Technol. Eng.* **3**, 1- 4
- [6] Ramalingam S, Rajendran S and Nattan R 2015 Influence of injection timing and compression ratio on performance, emission and combustion characteristics of Annona methyl ester operated diesel engine *Alexandria Eng. J.* **54**, 295- 302
- [7] Taremwa A, Kiplimo R and Wanji S 2016 Effect of compression ratio on the performance and emission of diesel dual fuel engine using biogas *IOSR J. Mech.Civil Eng.* **13**, 67- 74
- [8] Alqahtani A, Wyszynski M, Mazuro P and Xu H 2017 Evaluation of the effect of variable compression ratios performance on opposed piston 2-stroke engine *Combustion Engines.* **171**, 97- 105
- [9] Abhishek R G, Singh N P, Kolluri R V S K, Priyedarshi A and Singh S N 2015 Effect of compression ratio on the performance of diesel engine at different loads. *Inter. J. Eng. Res. Appl.* **5**, 62- 68
- [10] Ramachandran A and Waghmare A V 2016 Experimental investigation of the effect of compression ratio on the performance of a dedicated CNG engine *Inter. Res. J. Eng. Technol.* **3**, 312- 16
- [11] Mali A D and Yadav S D 2014 The effect of compression ratio on performance of 4- stroke spark ignition engine. *International Conference on Recent Advances In Science, Engineering And Technology, Pune, India.* pp. 98- 101
- [12] Kumar M L S D, Drakshayani S and Reddy K V K 2012 Effect of Fuel Injection Pressure on Performance of Single Cylinder Diesel Engine at Different Intake Manifold Inclinations. *Inter. J. Eng. Innovative Technol.* **2**, 20- 28
- [13] Mathur Y B, Poonia M P, Jethoo A S and Singh R 2012 Optimization of Compression ratio of diesel fuelled variable compression ratio engine. *Inter. J. Energ. Eng.* **2**, 99- 101
- [14] Chotai H 2013 Review on effect of varying compression ratio on performance and emissions of diesel engine fuelled with bio- diesel *Inter. J. Eng. Sci. Innov. Technol.* **2**, 561- 67
- [15] Naveen K, Pillai T P and Pon A 2014 Experimental investigation of variable compression ratio diesel engine using ziziphus jujuba oil. *Inter. J. Innov. Res. Sci. Eng. Technol.* **3**, 1134- 39
- [16] Bharwaj V, Singla V, Gaikwad P and Sharma G 2014 Study of performance characteristics of compression ignition engine fuelled with blends of biodiesel from used cottonseed oil. *Inter. Rev. Appl. Eng. Res.* **4**, 289- 96