

See discussions, stats, and author profiles for this publication at: <https://www.researchgate.net/publication/311822300>

Experimental investigation on discharge coefficient of notched piano key weir

Article in *International Journal of Scientific and Engineering Research* · January 2016

CITATION

1

READS

303

1 author:



[Prof. Dr. Saleh Issa Khassaf](#)

University of Basrah

143 PUBLICATIONS 293 CITATIONS

[SEE PROFILE](#)

Some of the authors of this publication are also working on these related projects:



PhD study [View project](#)



Determining the Coefficient of Discharge due to Flow over Composite Weir and below Gates [View project](#)

Experimental Investigation on Discharge Coefficient of Notched Piano Key Weir

Dr. Saleh Issa Khassaf, Dr. Laith Jawad Aziz, Zainab Ahmed Elkatib

Abstract : This study presents an experimental investigation to evaluate the effect of notch at sidewall of a Piano Key Weir (PKW) of type B and C on the discharge coefficient under free flow conditions. Model tests were conducted in a 15m long, 0.3m wide and 0.45m deep rectangular glass-walled flume. Eight physical models were prepared for both types: two traditional PKW type-B and C, and six notched models designed in similar dimensions to the traditional one. It was concluded that using staged PKW does not have a major effect on discharge capacity, water depth above the upstream apex (h_1) for type B is greater than type C relative to its upstream piezometric head.

Keywords : Notched Piano Key Weir, Staged PKW, Type B, Type C, Physical modeling, Free Flow, Discharge coefficient.

1 INTRODUCTION

Piano Key weir (PKW) is a hydraulically attractive alternative to linear overflow weirs, increasing the unit discharge for similar heads and spillway widths. Schleiss [1] and Lempérière et al. [2] present historical reviews on the PKW development. Depending on which PKW apexes have overhangs (upstream and/or downstream), PKW have been classified in to four types: type-A with symmetric or not symmetric overhangs, type-B with a single upstream overhang, type-C with a single downstream overhang (figure 1) and type-D without overhang. A staged weir, with two or more crest elevations, is one method of reducing the peak outflow discharge for frequent return-period storm regulations, while still providing sufficient discharge capacity to pass larger storm events[3]. The low stage weir is designed to pass moderate flow events and the higher stage weir is designed to add the capacity to pass the more extreme weir design flood[4].

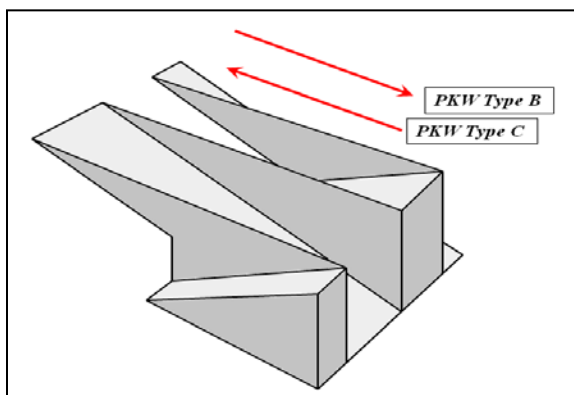

Figure 1 Piano Key Weir type B and C.

- Prof. Dr. Saleh Issa Khassaf, is currently one of staff at College of engineering in University of Basrah, Iraq. E-mail: salehissakh@gmail.com
- Assistant Prof. Dr. Laith Jawad Aziz, is currently one of staff at College of engineering in University of Kufa-Iraq. E-mail: laith.aljarrah@uokufa.edu.iq
- Zainab Ahmed Elkatib, is currently pursuing masters degree program in Civil engineering in University of Kufa, Iraq. E-mail: zainabaa.en13p@uokufa.edu.iq

This article is devoted to investigate the free flow hydraulic performance of notched Piano Key Weir. Results of notched PKW models are analyzed and compare it with the traditional ones for type B and C.

2 DESCRIPTION OF EXPERIMENTAL SET-UP

The experiments were carried out in an experimental straight flume 15m long, 0.3m wide and 0.45m deep rectangular. Flume discharge is measured by means of a pre-calibrated sharp-crested rectangular weir. All PKW models were made from acrylic glass sheets of 2.5 mm thick with a flat top crest. The location of notch is at the sidewall of PKW centered at the confluence of the two slope of keys (inlet and outlet). The minimum upstream water depth taken over the weir was 3 cm to ensure surface tension is negligible. At each run, upstream depth h and water depth at upstream apex were measured by using a rolling point gauge over the flume sidewalls of accuracy $\pm 0.3\text{mm}$. The data of the upstream water level (h) was measured at distance equal to 3.5 times the height of Piano Key Weir model ($3.5P$) from the outlet key apex in the upstream direction. A special attention must be given to the definition of h for a staged PKW due to multi crest levels for one weir. In this article, head-discharge data were collected discharges where the whole weir crest was working. When flow was conveyed over the entire PKW weir, h was taken relative to the high stage to compare the staged weirs to a traditional PKW with a single crest elevation, see figure (2). All tested models has a dam height ($P_d/P = 0.6$) of ($T_s/P \approx 0.02$) and made according to the recommendation of Lempérière et al. [2] for configuration of PKW type-B which is : $L/W = 5$, $W_i/W_o = 1$, $B/P = 2.4$, and B_o/B or $B_i/B = 0.5$. The tested models included two traditional PKW without notch one type-B and one type C, while the other six models are PKW with notch at sidewall its geometry shown in table 1 and figure 3. Figure 4 shows tested models during test.

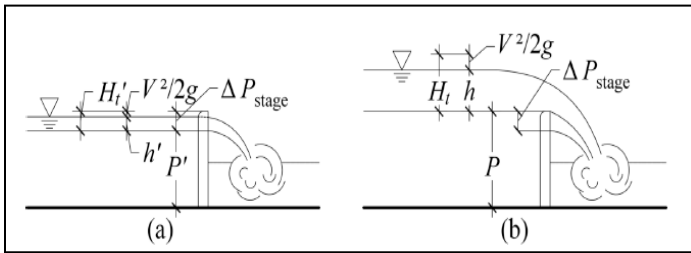

Figure 2 Hydraulic parameters for (a) weir flow isolated to the low stage and (b) over the entire weir.[5]

Table 1. Laboratory Model Test Matrix

Model No.	Model Type	Geometry	$\Delta P/P$	$\Delta L/L$
B1	Type B	Traditional	–	–
B2	Type B	With notch	$\Delta P/P = 0.2$	$\Delta L/L = 0.06$
B3	Type B	With notch	$\Delta P/P = 0.3$	$\Delta L/L = 0.06$
B4	Type B	With notch	$\Delta P/P = 0.2$	$\Delta L/L = 0.12$
C1	Type C	Traditional	–	–
C2	Type C	With notch	$\Delta P/P = 0.2$	$\Delta L/L = 0.06$
C3	Type C	With notch	$\Delta P/P = 0.3$	$\Delta L/L = 0.06$
C4	Type C	With notch	$\Delta P/P = 0.3$	$\Delta L/L = 0.06$

weir is used to compute the efficiency of a Piano Key Weir for free flow conditions.

$$Q_{act} = \frac{2}{3} C_{dw} W \sqrt{2g} H^{\frac{3}{2}} \quad (1)$$

3.1 Effect of the Staged Length ($\Delta P/P$)

The effect of notch discharge is minor for both types even when the ratio of dropped height increases ($\Delta P/P$ from 0.2 to 0.3). The increased in efficiency for type B is 3.5% at low heads for model B2 and for $H/P > 0.4$ the difference in flow efficiency became negligible, and about 6% to 3% for model B3 relative to traditional PKW type B as shown in figure 5. While for type C is less than 2% and about 4.5% for models C2 and C3 respectively relative to traditional PKW type C as shown in figure 6.

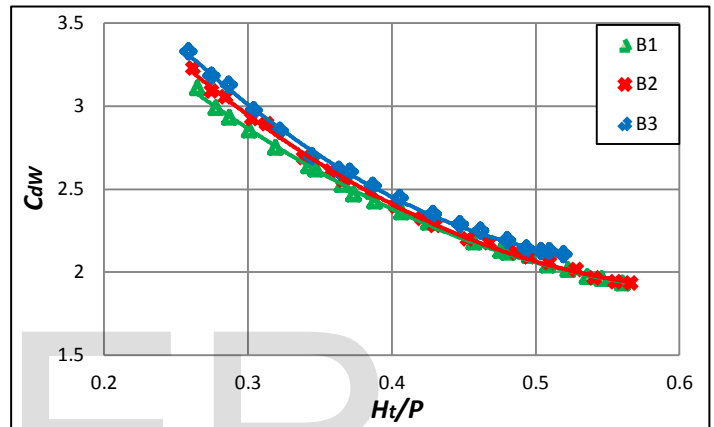

Figure 5 Variation of free overflow discharge coefficient (C_{dw}) versus H/P for various $\Delta P/P$ of PKW type B.

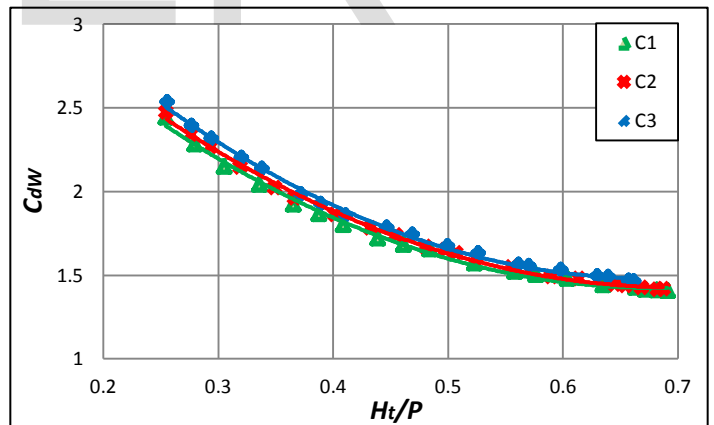

Figure 6 Variation of free overflow discharge coefficient (C_{dw}) versus H/P for various $\Delta P/P$ of PKW type C.

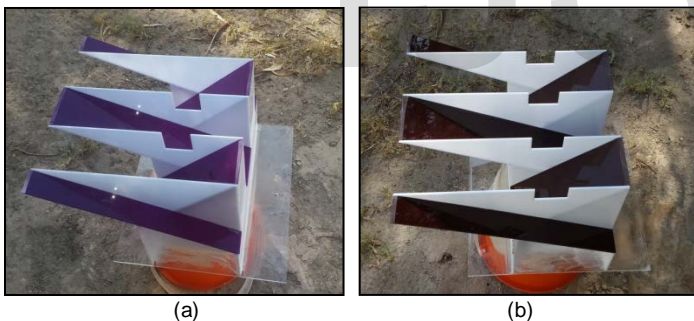

Figure 3 PKW models of (a) model B3 and C3, and (b) model B4 and C4.

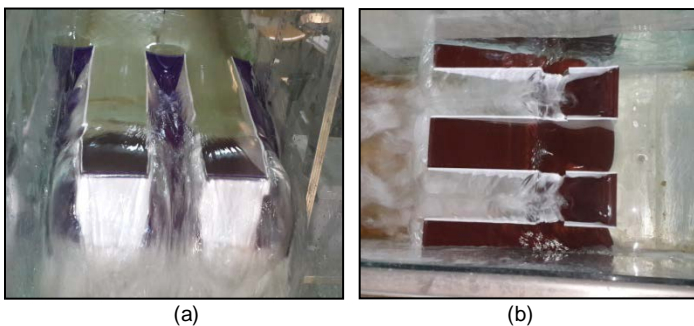

Figure 4 View of PKW models during test of (a) model B2 from downstream, and (b) model C4 from top.

3 RESULTS

The general discharge equation for a rectangular sharp-crested

3.2 Effect of the Staged Length ($\Delta L/L$)

Two PKW models with the same dropped height but with different length of staged crest were tested for each type to investigate the length effects of the lowered crest on the weir efficiency. The performance is similar to the height effects of the dropped crest and the behavior of the two types is similar. For type B, models B2 ($\Delta L/L = 0.06$) and B4 ($\Delta L/L = 0.12$) is more efficient than traditional PKW type B (B1) about 4% and 9% at low heads and decreased to zero and 2% at high heads respectively as shown in figure 7. While for type C is less than

2% and about (6.7- 4.5)% for model C2 and C4 respectively relative to traditional PKW type C as shown in figure 8.

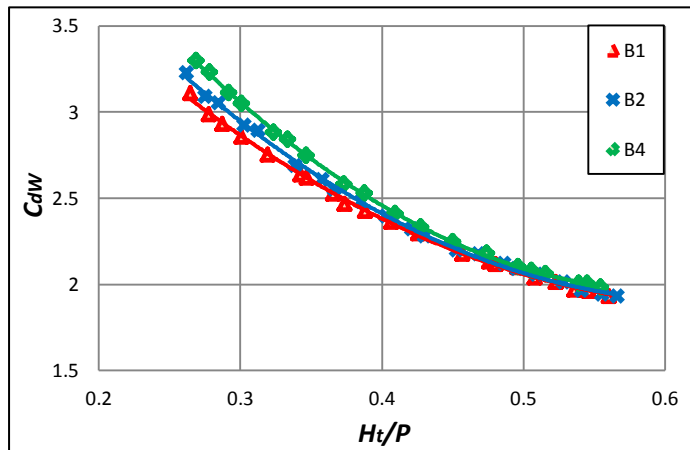

Figure 7 Variation of free overflow discharge coefficient (C_{dW}) versus H_t/P for various $\Delta L/L$ of PKW type B.

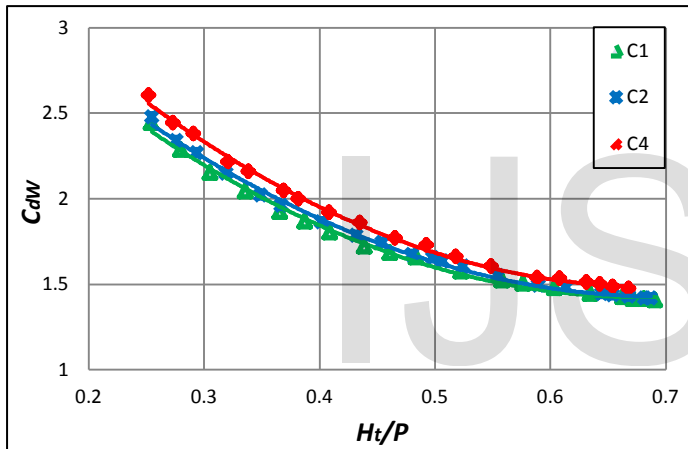

Figure 8 Variation of free overflow discharge coefficient (C_{dW}) versus H_t/P for various $\Delta L/L$ of PKW type C.

4 CONCLUSIONS AND RECOMMENDATIONS

The important conclusions that can be drawn from the this study are :

- Using notch at sidewall of PKW type B effects the efficiency slightly, dropping 6% of the crest by 20% of the height ($\Delta P/P = 0.2$ and $\Delta L/L = 0.06$) led to less than 4% to zero gain in capacity. Increasing the dropped height more ($\Delta P/P = 0.3$) gives about 6 % to 3% gain, while increasing the dropped crest length more ($\Delta L/L = 0.12$) gives about 9% to 2% gain.
- Using notched PKW type C at sidewall effects the efficiency slightly, lowering 6% of the crest by 20% of the height ($\Delta P/P = 0.2$ and $\Delta L/L = 0.06$) increases C_{dW} about 2% to zero. Increasing the lowered height more ($\Delta P/P = 0.3$) introduces about 4.5% gain, while increasing the lowered crest length more ($\Delta L/L = 0.12$) gives approximately 6.7% to 4.5% gain.

- The water depth above the upstream apex (h_1) is constant along the weir width and it is always less than the upstream piezometric head h . For type B it's about (91% of h), while for type C it's about (83 to 86% of h).

NOMENCLATURE:

Variable	Description	Dimension
B	lateral weir crest length	L
B_o	upstream (outlet key) overhang crest length	L
B_i	downstream (inlet key) overhang crest length	L
C_{dW}	discharge coefficient	-
g	gravity acceleration	LT^{-2}
H_t	total upstream water head	L
h	upstream flow depth	L
h_1	flow depth above upstream apex	L
h'	upstream flow depth above staged crest	L
P	weir height	L
P'	height of staged crest	L
P_d	dam height	L
T_s	side wall thickness	L
Q	free weir flow discharge	L^3T^{-1}
W	total width of the PKW	L
W_i	Inlet key width (sidewall to sidewall)	L
W_o	outlet key width (sidewall to sidewall)	L
L	total weir crest length	L
ΔP	depth of staged crest	L
ΔL	length of staged crest	L

REFERENCES

- Schleiss, A. J., From Labyrinth to Piano Key Weirs - A historical review. Proceedings of the International Conference(Labyrinth and Piano Key Weirs - PKW 2011), Liège, Belgium, CRC Press, London, pp. (3-15), 2011.
- Lempérière, F. , Vigny, J.-P. and Ouamane, A. , "General comments on Labyrinths and Piano Key Weirs: The past and present", Proceedings of the International Conference Labyrinth and Piano

- Key Weirs 2011, Liège Belgium, CRC Press, London, pp.(17-24), 2011.
- [3] Dabling, M. R. , "Nonlinear Weir Hydraulics", M.Sc thesis, Utah State University, Department of Civil and Environmental Engineering, Logan, Utah, USA), 2014.
- [4] Paxson, G. , Campbell, D. and Monroe, J., "Evolving Design Approaches and Considerations for Labrinith Spillways", 21st Century Dam Design-Advances and Adaptations, San Diego, California, USA, April, pp. (1645-1666), 2011.
- [5] Dabling, M.R., Tullis, B.P., and Crookston, B.M. , "Staged labyrinth weir hydraulics", Journal of Irrigation and Drainage Engineering, ASCE, Vol. 139, No. 11, May, pp. (955-960), 2013.

IJSER