

Implementing Primary Synchronization Channel in Mobile Cell Selection 4G LTE-A Network

Murtadha Ali Nsaif Shukur¹, Kuldip Pahwa², H. P. Sinha³

¹ M. Tech Final Year Student, ² Professor, ³ Head of Department Electronics and Communication Engineering,

^{1, 2, 3} Department of Electronics and Communication Engineering,

^{1, 2, 3} Maharishi Markandeshwar University, Mullana, Ambala, Haryana, INDIA

Abstract

To increasing demand for higher throughput and data rates and high speed processing of data, the wireless communication systems need to operate in wider bandwidths. Long term Evolution-Advanced with carrier aggregation enables operators to maximally and optimally utilize their available spectrum resources for increased data rates and enhanced user experience. The Cell selection is the process of determining the cell(s) that provide service to each mobile station. One interesting challenge in the physical layer of LTE-A is how the mobile unit immediately after powering on, locates a radio cell and locks on to it. This paper, presents how the mobile unit establishes this connection with the strongest cell station in vicinity. To do this, the mobile unit has to overcome the challenges of estimating the channel to communicate with the cell site and frequency synchronization. Also, multiple mobile units communicate to the same receiver and from various distances. Hence, it is up to the mobile to synchronize itself appropriately to the base stations. LTE-A uses two signals, the Primary Synchronization Signal(PSS) and the Secondary Synchronization Signal (SSS), sequentially to determine which of the available cell sites a mobile would lock in. Also, its present the types of synchronization channel (SCH) like P-SCH and S-SCH.

Keywords – LTE, LTE-A, PSS, SSS, cell searching and selection.

I. Introduction

The exploding growth of the mobile internet and related services in the past few years has fuelled the need for more and more bandwidth. The demand for higher data rates in wireless has triggered the design and development of new data minded cellular standards such as WiMAX, 3GPP's High Speed Packet Access (HSPA) And LTE standards Long term Evolution (LTE) is the result of the standardization work done by the 3GPP to achieve a new high speed radio access in the mobile communications frame.

3GPP is a collaboration of groups of telecom associations working on Global System for Mobile Communication (GSM) [1]. 3GPP published and introduced the various standards for IP based system in Release 8, which is termed Long Term Evolution and abbreviated as LTE. Initially, LTE was introduced in the Release 8 in 2008. In 2010, the Release 9 was introduced to provide enhancements to LTE and in 2011, its Release 10 was brought as LTE-Advanced, to expand the limits and features of Release 8 and to meet the requirements of the International Mobile Telecommunications-Advanced (IMT-Advanced) of ITU-R for the fourth generation (4G) of mobile technologies, and the future operator and end user's requirements. The LTE-Advanced; (LTE-A) extends the features of LTE in order to exceed or at least meet the IMT-Advanced requirements. It should be a real broadband wireless network that behaves as an advanced fixed network like FTTH (Fiber-To-The-Home) but with better quality of service [2]. The key goals of LTE-Advanced are: Support of asymmetrical bandwidths and larger bandwidth (maximum of 100MHz); Enhanced multi-antenna transmission techniques. There are some of the characteristics of this type of networks are [3]: Self-organizing networks, Intelligent Node Association, Support for relays, Adaptive Resource Allocation, Multicarrier (spectrum aggregation) and Coordinated Beam forming. LTE-Advanced is intended to support further evolution of LTE and to establish EUTRAN as an IMT-Advanced technology. LTE-A also known as LTE release 10 is set to provide higher bitrates in a cost efficient way and at the same time also focus on higher capacity, i.e.:

- Increased peak data rate DL 3Gbps, UL 1.5Gbps.
- Increased number of simultaneously active subscribers.
- Improved performance and higher spectral efficiency.
- Worldwide functionality and roaming.
- Compatibility of services.

- Inter working with other radio access systems.

The ability to provide services in a cost-effective manner is one of the most important building blocks of competitive modern cellular systems. Usually, an operator would like to have a maximal utilization of

the installed equipment, that is, to maximize the number of satisfied customers at any given point in time. This paper addresses one of the basic problems in this domain, the cell selection mechanism. This mechanism determines the base station (or base stations) that provides the service to a mobile station—a process that is performed when a mobile station joins the network (called cell selection), or when a mobile station is on the move in idle mode (called cell reselection, or cell change, in HSPA) [2]. In most current cellular systems the cell selection process is done by a local procedure initialized by a mobile device according to the best detected SNR. In this process, the mobile device measures the SNR to several base stations that are within radio range, maintains a “priority queue” of those that are best detected (called an active set), and sends an official service subscription request to base stations by their order in that queue. The mobile station is connected to the first base station that positively confirmed its request. Reasons for rejecting service requests may be handovers or drop-calls areas, where the capacity of the base station is nearly exhausted[4]. There are many types of cells like : Microcells, Macrocells, Femtocells, Picocells, Satellite (world wide coverage).

II. System Description and Design Considerations

The diagram of the downlink OFDMA air interface is shown in Figure 1. In the OFDMA system, modulated bits are converted from serial to parallel first, and then mapped to different subcarriers. After IFFT, the output signals are converted back to serial signals called an OFDM symbol. Cyclic prefix (CP) is attached to the beginning of the OFDM symbol before transmission.

Subcarrier spacing of 15 kHz is used in the 3GPP LTE-A system [5].

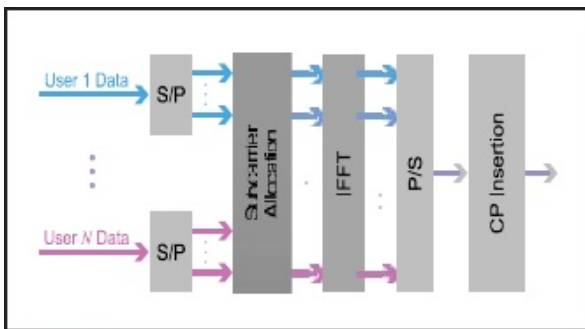

Figure 1: OFDMA air interface in 3GPP LTE-A systems [5]

In UMTS systems, the cell search in LTE-A systems will enable the terminal to obtain frame and symbol timing, frequency offset and the cell ID. However, cell searching in LTE-A systems has to consider multiple transmission bandwidths (UMTS has a fixed

bandwidth of 5MHz, while LTE systems support (1.25, 2.5, 5, 10, 15 and 20 MHz) bandwidths. And LTE-A systems its used (Up to 20-100MHz) Moreover, cell search procedure in LTE-A systems should be completed with low processing complexity at the terminal and within a much shorter time than that in UMTS systems. All of these requirements are expected to be fulfilled with system overhead on par with UMTS systems. In this Part It can be describe, a synchronization channel that is common to all cells in the system irrespective of the bandwidth being used in the cell, since this will yield faster cell search

and lower complexity. Therefore, it is agreed that the synchronization channel should be transmitted using the central 1.25 MHz bandwidth regardless of the entire band- width of the system [6]. While, the same synchronization channel is mapped to the central part of transmission bandwidth for all system bandwidths. The central 1.25 MHz corresponds to 76 subcarriers with subcarrier spacing of 15 kHz. The downlink frame structure of the LTE-A system is shown in Figure 2. Each radio frame (10 ms) is divided into 10 sub-frame of 1 ms. each sub- frame consists of 2 slots. There are 7 OFDM symbol per slot. There are two kinds of synchronization channels (SCH): primary SCH (P-SCH) and secondary SCH (S-SCH). P-SCH and S-SCH symbols are time division multiplexed. Each radio frame contains two equal-spaced pairs of P-SCH and S-SCH symbols. For coherent detection of S-SCH symbols, P-SCH and S-SCH symbols are placed adjacent to each other in the last two OFDM symbols of the first slot within a sub-frame [7]. In order to provide good timing detection performance, the synchronization sequence in UMTS systems should have very good auto-correlation. Due to this property, the Golay sequence was chosen as the synchronization sequence for UMTS systems. For LTE-A systems, the synchronization sequence is mapped to the central band of entire bandwidth due to the OFDMA based downlink air interface. However, the terminal does not know the downlink timing of the system at the beginning of the cell search; hence, frequency domain processing (e.g., DFT) based timing detection at each sample will make the cell search processing complexity too high for the terminal. In order to obtain good timing detection performance with low complexity.

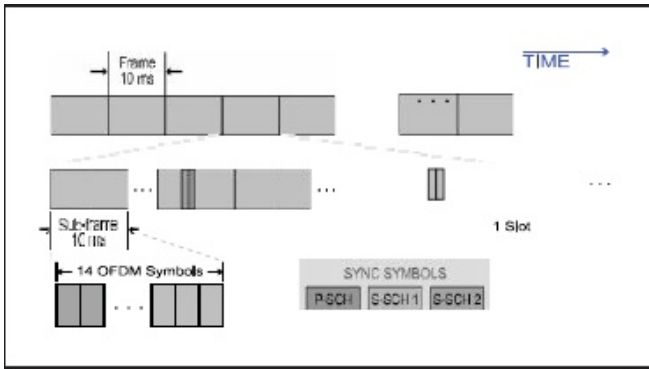

Figure 2: Downlink frame structure of 3GPP LTE-A systems [5]

III. Localized mapping and distributed mapping

In SC-FDMA each data modulation symbol is spread out onto all carriers. Distributed/ interleaved subcarrier mapping mode is robust against the frequency selective fading information is spread across entire signal bandwidth. Thus it exploits frequency diversity effectively and at the same time peak average power ratio is lower than localized subcarrier mapping mode. Localized subcarrier mapping achieves multi-user diversity in presence of frequency selective fading as user can be assigned subcarrier according to their channel gain, transmit and receive of SC-FDMA data between two users, User A and User B was performed using CAZAC (Constant Amplitude Zero Autocorrelation) sequences for channel estimation[8]. The channel was estimated using Zadoff-Chu sequences and this channel was undone at the receiver end. Localized subcarrier mapping was used. The SC-FDMA transmitter system based on which the system was implemented is presented in Figure 3. For the simulation the factors that were considered are as follows:

FFT length: 128, IFFT length for subcarrier mapping: 512, Input Data: 16 QAM, Reference Signal CAZAC Sequence for channel estimation, No. of users: 2 with different channel conditions.

The localized SC-FDMA of the inputs to IFFT are given as,

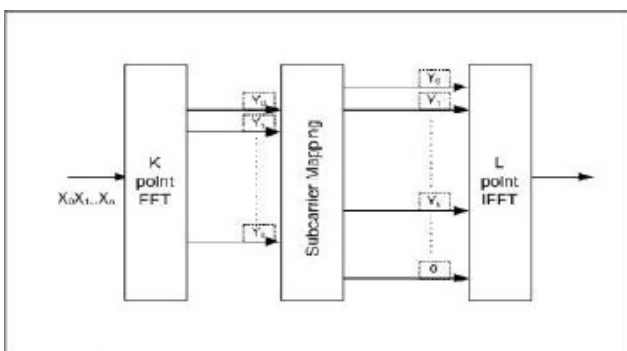

Figure 3 SC-FDMA transmitters [8]

IV. Zadoff-Chu: is a Complex-valued mathematical sequence which, when applied to radio signals, gives rise to an electromagnetic signal of constant amplitude, whereby cyclically shifted versions of the sequence imposed on a signal result in zero correlation with one another at the receiver. A generated Zadoff-Chu sequence that has not been shifted is known as a "Root Sequence" [9].

V. Design of Synchronization Channels

There are two types of Synchronization channels:

1) P-SCH Symbol Structures: The purpose of P-SCH is to facilitate the timing and frequency offset detection. To achieve this purpose, three P-SCH symbol structures have been proposed: repetitive pattern, symmetrical-and-periodic pattern, and non-repetitive pattern. A P-SCH symbol structure with time domain repetitive blocks was proposed in [5], [6]. In the example shown in Figure 4, the P-SCH symbol in the time domain contains K (K = 2 or 4) blocks of equal length, and the cyclic prefix (CP) is attached at the beginning of the P-SCH symbol. As shown in Figure 5, a P-SCH symbol structure with a symmetrical-and-periodic pattern was proposed in [5] as describe an a LTE-A native to the P-SCH symbol structure with a repetitive pattern. Block B in Figure 4 is symmetrical (reverse) to block A. A P-SCH symbol structure with a non-repetitive pattern, as shown in Figure 6. Unlike the P-SCH symbol with a repetitive pattern which is discussed above, the P-SCH symbol with a non-repetitive pattern can be generated using consecutive subcarriers in the frequency domain. There are two methods to generate the time domain repetitive and symmetrical-and-periodic P-SCH symbols: frequency domain and time domain. In case of frequency domain, the synchronization sequence is mapped to the central subcarriers in an equidistant manner. This is shown in Figure 7. Using the frequency domain mapping, any complex frequency domain synchronization sequence can be used to generate the K repetition blocks pattern. In case of

time domain, According to the property of DFT, the symmetrical-and-periodic pattern can be generated when a real synchronization sequence is used. In the time domain method, on the other hand, a time domain synchronization sequence is pre-coded by a DFT and then mapped to localized (consecutive) subcarriers of the same symbol. Finally, a P-SCH symbol is generated after IDFT.

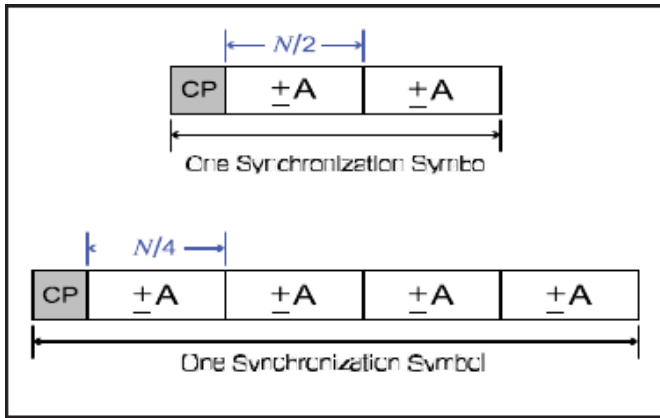

Figure 4 P-SCH symbol structure with repetitive pattern: (a) 2 repetitions; (b) 4 repetitions [7]

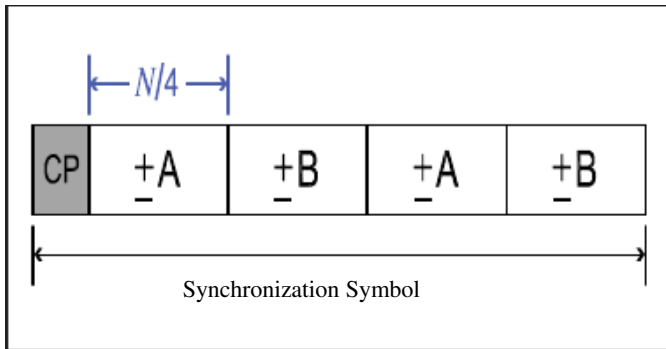

Figure 5 P-SCH symbol structure with symmetrical and-periodic pattern [5]

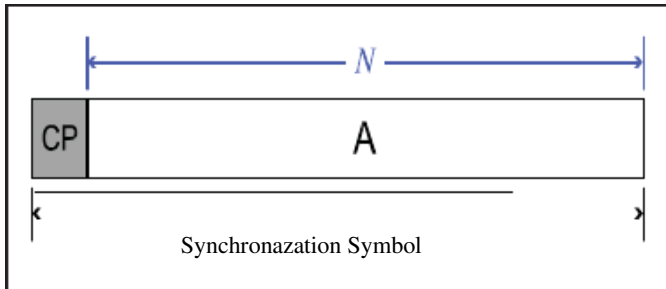

Figure 6 P-SCH symbol structures with non-repetitive pattern [5]

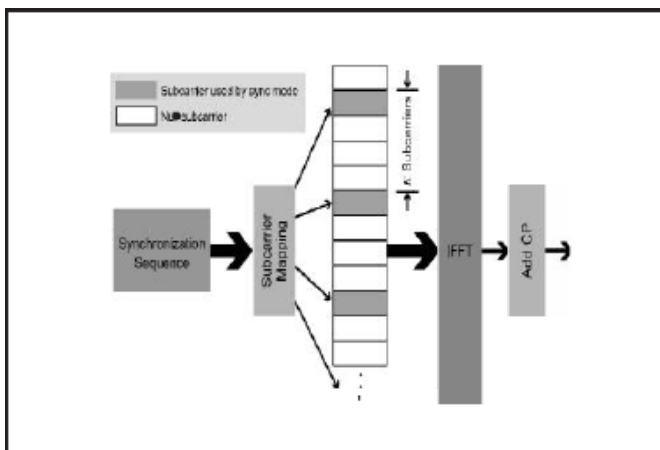

Figure 7 Generation of P-SCH symbols in the frequency domain approach [5], [6].

2) S-SCH Symbol Structure: The design and implementing of S-SCH needs to supports a sufficient number of hypotheses to carry the following information: 510 cell IDs (jointly with P-SCH symbols) and the number of transmit antennas used for broadcast channel (1 bit). Suppose that three different

types of P-SCH sequences are used in the system, hence the S-SCH needs to support 340 (i.e., $2 \times 510/3$) hypotheses. Since there are at most 76 subcarriers can be used for S-SCH, the only solution to support such a large number of hypotheses is to use a fixed equal-distant inter-leaving of two short sequences with length G , say $SG(1)$ and $SG(2)$, as shown in Figure 8 [10]. With this structure, the number of supported hypotheses is the product of numbers of different $SG(1)$ and $SG(2)$, which approximately equals to G^2 . Since there are more than one P-SCH symbols in a radio frame as shown in Figure 2, the P-SCH symbols can only provide symbol timing, but not frame timing (due to ambiguity of multiple same P-SCH symbols). Two different S-SCH symbols can be generated by swapping the frequency locations of $SG(1)$ and $SG(2)$. Upon detection of the an S-SCH symbol, the terminal can obtain the frame timing as well.

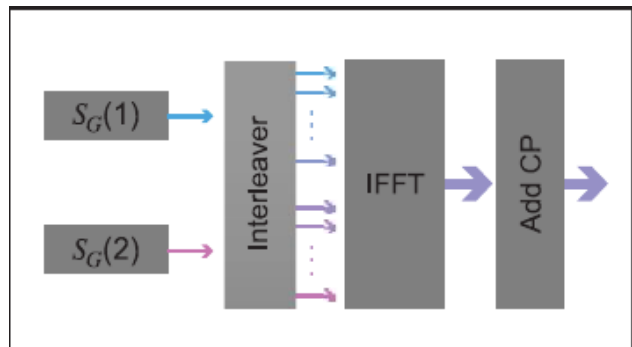

Figure 8. General S-SCH Symbols [5].

VI. Cell Search procedure in LTE-A

In the method described, the cell ID (Cell- specific scrambling code) is directly identified only the SCH without reference signal. There are four steps to implementing the cell searching in LTE-A networks [11]:

Step 1: In this step and by processing the P-SCH symbols, OFDM symbol timing and the carrier frequency offset are detected. Depending on the P-SCH symbol structure, one of three methods of timing and frequency offset detection can be used: auto-correlation, cross-correlation, or hybrid detection. Note that these detection methods can be applied to both time and frequency domain synchronization sequences.

Auto-correlation based detection: This method can be applied to P-SCH symbols with repetitive or symmetrical- and-periodic pattern. In the

autocorrelation the coherent detection cannot be applied to detection the SCH. In received signal is multiplied by its conjugate after a delay of one repetition block and summed over one repetition block. The search window slides along in time as the receiver searches for a P-SCH symbol. MMSE-type

detection is used to obtain the downlink P-SCH symbol timing. The sample timing with the largest peak in the block-wise auto-correlator output is selected as the P-SCH symbol timing. While frequency offset can be estimated easily from the output of the auto-correlation as well.

Cross-correlation based detection: This method can be applied to any P-SCH symbol structure. In this method, the transmitted P-SCH sequence is used to correlate the received P-SCH signals. The cross-correlation metric is used to obtain the timing and frequency offset. It is known that cross-correlation detection suffers in the presence of frequency offset. To mitigate this problem, the cross-correlation can be partitioned into M parts [12]. The advantage of the method is its reliable estimation of timing. However, its main drawbacks are higher complexity compared to auto-correlation based detection.

Hybrid detection: This method can be applied to P-SCH symbols with repetitive or symmetrical-and-periodic pattern. First, the coarse timing and frequency offset are estimated by helping the auto-correlation detection. The received signal is then compensated with the estimated phase, and cross-correlation is performed to obtain a refined timing offset estimate. Hybrid detection combines the advantages of auto- and cross- correlation based detection and has a lower complexity compared to cross-correlation based detection. [11] [12].

Step 2: In this step the S-SCH symbols are processed in the frequency domain to detect the cell ID group (one out of 170), frame timing and cell-specific information (such as number of antennas used by BCH).

Step 3: In this step it can be implementing one-to-one mapping between 3 P-SCH sequences (one of the 3 Cell IDs in each Cell ID group) and downlink reference signals are applied in the system. By processing the downlink reference signals, the cell ID (one out of 3) is derived within the cell ID group obtained in the step 2.

VII. Cell Selection

When subscriber power on the mobile device, in most case the device is under a circumstance where it sees many base stations (eNode B) around it. In some cases UE would be surrounded not by the multiple base

station from one system operator but by the multiple base station from multiple system operators. Out of those many base station, UE can camp on (register) to

only one base station. Then the question is which specific single base station the UE have to register. For this UE goes through a specific decision making process to pick up a specific base station (cell) to register, this specific decision making process is called 'Cell Selection'.

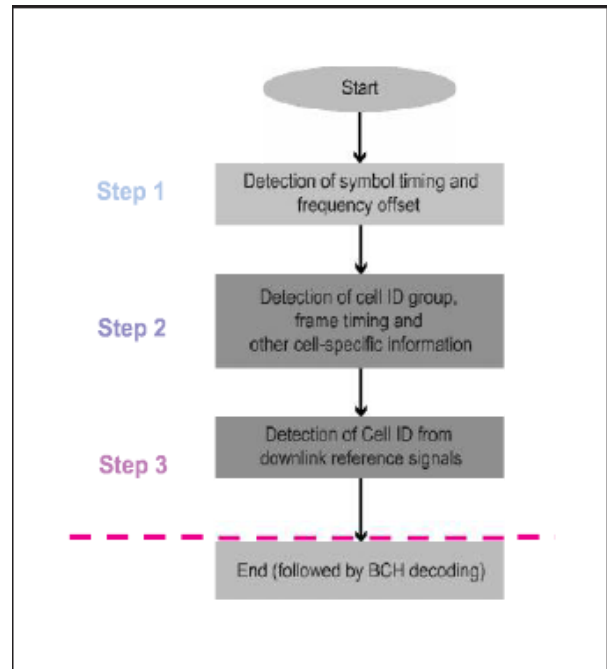

Figure 9 Hierarchical cell search procedure [11].

VIII. PSS (Primary Synchronization Signal)

Detection

When the UE (User Equipment) is powered on. UE monitors the central part of the spectrum regardless of its bandwidth capability. The UE has in its memory a copy of the three possible Primary Synchronization signals. The first step that a UE has to perform before proceeding with further signal processing is the determination of the symbol start. The UE performs this detection by using a sliding window method with a delay length of symbol length (here 64) [13]. In this method, the received signal is processed with a delayed version of itself- the ratio of the aggregated cross correlation (between the input to the delay line and the output to the delay line) to the aggregated auto correlation at the output of the delay over a set of samples helps in detecting the symbol start. Now the UE has to match the received signal to one of the three sequences it knows. The UE has to perform this with two considerations:

1. The signal has gone through a phase rotation while travelling from the radio cell to the UE.
2. The signal has undergone degradation due to the channel and the UE has to estimate the channel for use

with the Secondary Synchronization Signal, the PSS with root 25 is the transmitted signal from the radio

cell. According on the formula:

Where the Zadoff-Chu root sequence index u is given by Table 1.

Table 1. Root Indices for the Primary Synchronization Signal [9].

Root index (u)	
0	25
1	29
2	34

The PSS Estimation of symbol for start using cross and autocorrelation in figure below.

Figure 10 Estimation of symbol start using cross and autocorrelation [9] [11] [12]

Also, the UE knows the position of the amplitude maximum peak when there is no offset and depending on the position of the peak it finds when it detects the PSS it is able to calculate the offset. In this case, it was determined that for every 15 kHz frequency offset, the peak moves by one frequency bin. Now, the UE has determined the offset that it has to adjust when it receives the SSS. Now, that the UE knows which PSS sequence is being received and it has a known reference of the signal and has also determined any frequency offset, the UE can now estimate the channel using its known reference of the original signal. If the transmitted sequence is X , the received sequence is Y after channel effects, and the channel is denoted by H , in frequency domain, $Y=XH$ and the channel H can be determined to be $H=Y/X$. The inverse of this known estimate of the channel can then substituted in the

received sequence. Figure 10 shows the representation of the actual and estimated channel. At the end of this step the UE knows:

1. Symbol boundary.
2. Cell ID index ($N(2)ID$).
3. Sub frame timing describes that in FDD systems the

PSS is transmitted in subframe 0 or Subframe 5. So, with the detection of PSS, the UE knows it is synchronized with either subframe 0 or subframe 5. Determination of whether it is subframe 0 or subframe 5 will enable frame timing synchronization which will be performed with the detection of SSS.

4. Channel Estimate.

IX. SSS (Secondary Synchronization Signal) Detection

The sequence $d(0), \dots, d(61)$ used for the secondary synchronization signal is an interleaved concatenation of two length-31 binary sequences. The concatenated sequence is scrambled with a scrambling sequence given by the primary synchronization signal. The combination of two length-31 sequences defining the secondary synchronization signal differs between subframe 0 and subframe 5 according to [11]:

Where $0 \leq n \leq 30$

The above equation clearly indicates that the SSS is different for subframe 0 and subframe 5. So, detection of SSS will enable UE to determine the frame timing as well. The detection of SSS is a coherent process. Since the UE has determined an estimate of the channel from the PSS, it now removes the effects of the channel before it detects the SSS. The SSS and PSS are closely located in time to enable the coherent detection [14]. known to the UE and can be descrambled from the received signal, So, has only one unknown m_0 in $s(m_0)(n)$.

X. Simulation and results

From block diagram in figure 10. And the formula in primary synchronization signal, we can simulate the result by help the table 1. In PSS its provide the tree roots (25, 29, 34), figure 11. Which explain Transmitted signal, according the relation between samples and Amplitude signals.

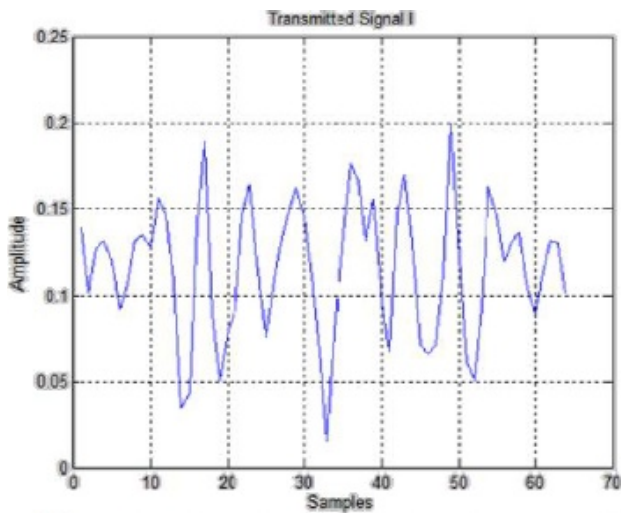

Figure 11 Transmitted signal

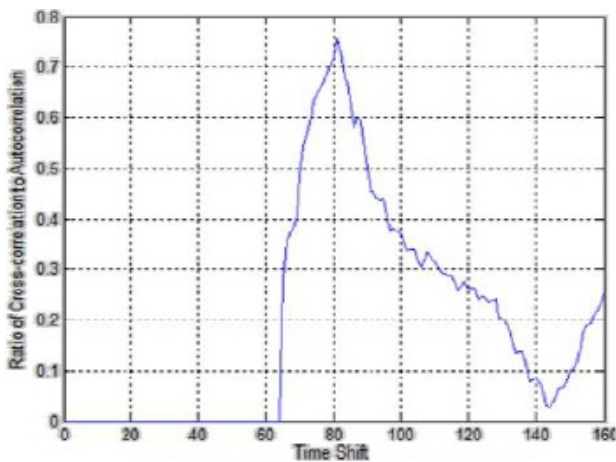

Figure 12 Relation between the Time Shift Vs Ratio Cross-correlation to Auto correlation

The Figures (13, 14, 15) its explain the PSS-CAZAC (Constant Amplitude Zero Autocorrelation) sequence of length 63 Vs roots 25, 29, 34 its defined the different numbers of complex sequence in real and imaginary part, which all the Zadoff-chu have amplitude is 1.

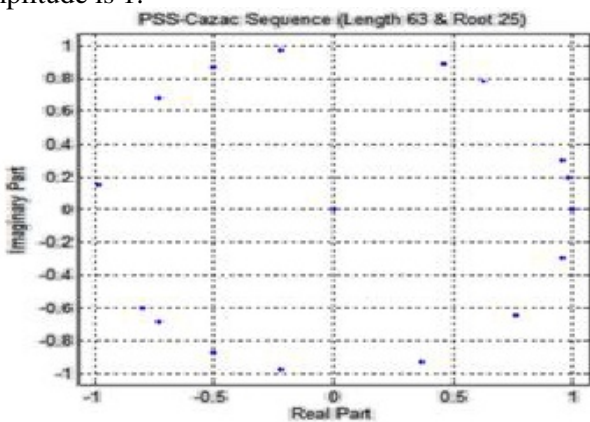

Figure 13 Relation between the Real Vs Imaginary part in PSS-CAZAC with length 63 and root 25

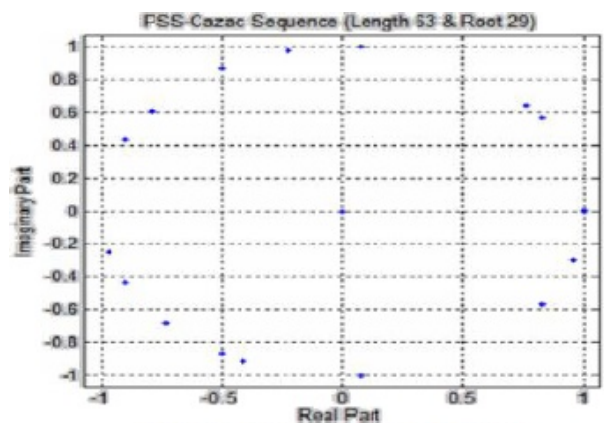

Figure 14 Relation between the Real Vs Imaginary part in PSS-CAZAC with length 63 and root 29

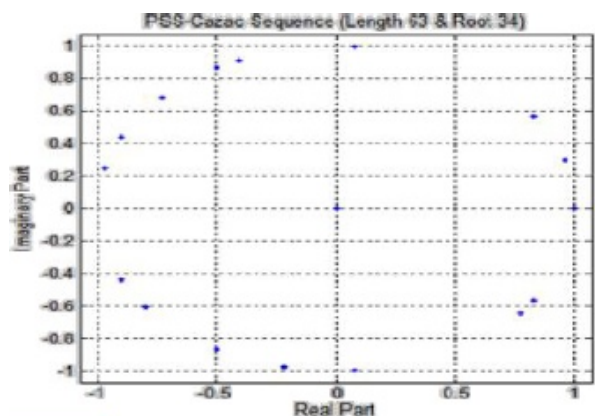

Figure 15 Relation between the Real Vs Imaginary part in PSS-CAZAC with length 63 and root 34

XI. Conclusion

In this paper, we presented an Implementing PSS in mobile cell searching 4G, which has been proposed cell search and selection for 4G LTE-A system. The proposed includes synchronizations and cell identification by using the Zadoff-chu Algorithm and standard roots, when the based on P-SCH and S-SCH cell specific pilot symbols, respectively. Frequency synchronization performance can be improved through oversampling SCH at the receiver. When the cell identification is obtained by combining the optimum ratio with the frequency domain differential cross-correlations and autocorrelation. In this work, we presents how the mobile unit establishes this connection with the strongest cell station in vicinity, to do this Simulation results confirm the performance improvement of the proposal of PSS and SSS.

References

[1] 3GPP, “3rd Generation Partnership Project, Technical specification group radio access network”, Physical channels and modulation (Release 8), 3GPP TS 36.211.

- [2] D. Amzallag, R. Yehuda, D. Raz, and G. Scalosub, "Cell selection in 4G cellular networks", IEEE Transactions on mobile computing, vol. 12, no. 7, July 2013, pp.1443-1455.
- [3] 3GPP, "3rd Generation Partnership Project, Technical specification group radio access network", Multiplexing and Channel Coding (Release 8), 3GPP TS 36.212.
- [4] Hassen, and T. Wolde, "Synchronization in Cognitive Overlay Systems", International journal of electrical engineer, vol.19, no.9, 2012, pp.112-130.
- [5] Y. Tsai, G. Zhang, D. Grieco, F. Ozluturk, "Cell search in 3GPP LTE-A systems", IEEE vehicle and technology, Inter Digital Communications Corporation. Columbia University, vol.6, no.7, 2007, pp.23-29.
- [6] T. Kudo And T. Ohtsuki, "Cell Selection Using Distributed Q-Learning in Heterogeneous Networks", IEEE Signal and Information Processing Association Annual Summit and Conference (APSIPA), vol.16, no.3, Nov. 2013, pp.1-6
- [7] Y. Shen, T. Luo, and M. Win, "Neighboring Cell Search Techniques for LTE Systems", Communications (ICC), 2010 IEEE International Conference on. 2010, ISSN 1550-3607, 2012, pp. 1-6
- [8] K. SoonKim, S. Woong Kim, Y. SooCho, And J. YoungAhn, "Synchronization and Cell Search Technique Using Preamble for SC-FDMA Cellular Systems", IEEE Transactions on vehicular technology, vol. 10, no.5, 2007, pp.1-16.
- [9] N. Paravastu and A. Samavedam, " Mobile cell search and synchronization in LTE", International Journal of Electrical Engineering, San Diego State University, 2011, pp.30-35.
- [10] J. Won, K. Kijun, J. Young Jin, S. Kwang And S. Kim, "Synchronization Signal Design for Cell Search in 3GPP-LTE HCN", IEEE Signal Design and its Applications in Communications (IWSDA), 2011 Fifth International Workshop, ISBN 978-1-61284-047-5, vol.17, no.6, 2011, pp.150-153.
- [11] J. Moon and D. Cho, "efficient cell selection algorithm in hierarchical cellular networks: multi-user coordination", iee communications letters, vol. 14, no. 2, feb.2010, pp. 122-126.
- [12] M. Mazrooei sebdani and M. Javad Omid, "Detection of an LTE Signal Based on Constant False Alarm Rate Methods and Constant Amplitude Zero Autocorrelation Sequence", Telecommunication Research center (ITRC), Department of Electrical and Computer Engineering, Isfahan University of Technology, Isfahan, 84156-83111, Iran, 2012, pp. 1-6.
- [13] C. Sun, J. Jiang, G. Lu, " Primary synchronization Channel Design for OFDM Based Mobile Communication Systems", Proceedings of the 2012 International Conference on Cybernetics and Informatics in Electrical Engineering, vol. 163, 2013, pp. 1623-1630.
- [14] D. Liao, D. Qiu, and A. Elhakeem, "Coding based Synchronization Algorithm for Secondary Synchronization Channel in LTE", Communication Software and Networks, International Conference on 01/2009, ISBN: 978-0-7695-3522-7, vol.3, 2009, pp. 776-784.



Muratadha Ali Nsaif Shukur is a student Final year M.Tech (Electronic and Communication Engineer) at MM University, Mullana, He has received his B.Tech (Communication Engineer) from Technical Collage of Najaf and Diploma in (Electrical branch) from Technical Institute of Najaf, Iraq.